

MIDBROOK STEEL GARDEN BUILDING INSTALLATION GUIDE

Issue 1



BE SAFE WHEN WORKING AT HEIGHT

Ensure you conform to the latest Work at Height Regulations. For more details, visit:

www.hse.gov.uk/work-at-height

If in doubt at any stage

Please contact our Technical Support for additional support or advice.



01335 370128

HEALTH AND SAFETY STATEMENT



- ▶ It is essential that a minimum of two people are present during the installation in order to safely handle and move the steel framework and roofing panels due to their weight and size.

The steel work and roofing sheets can contain sharp edges, always ensure you wear cut resistance gloves when handling these items. If you require to venture onto the roof, ensure you follow the latest working at height legislation. <https://www.hse.gov.uk/work-at-height/>

PPE REQUIRED

- ▶ Cut resistant gloves
- ▶ Safety glasses
- ▶ Safety helmet
- ▶ Safety footwear

REQUIRED TOOL LIST

1. Impact driver complete with PZ2, PH2, PH3 bits and 8mm AF Hex bit
2. Cordless drill complete with 3mm, 4mm & 6mm steel drill bits
3. 2 x 24mm sockets or spanners
4. 6" spirit level
5. Hack saw with fine blade suitable for steel
6. Fine bladed wood hand saw
7. Sealant gun
8. Nylon Mallet
9. Tape Measure
10. Marker Pen
11. Counter sink
12. Pop Rivet Gun (Optional)

POSITIONING & BUILDING REGULATIONS

- ▶ There are several factors to consider when deciding where in a garden to place the new building.
- ▶ From a practical point of view there needs to be a space of at least 600mm at the sides and the rear to allow space for construction and for future maintenance such as cleaning out guttering. It must be pointed out that the Coastline Cladding is not supposed to be installed on buildings closer than 1m away from a boundary. Also buildings with front, or possibly side extending roof overhangs should not be positioned so that the overhang oversails a boundary.
- ▶ The same applies even to guttering and is legislated against in part under the Party Wall Act.
- ▶ Also building regulations apply, but only to part of our model range. A building of more than 15m² floor area cannot be sited closer than 1m to a boundary without building regulation approval. This only applies to our 6m x 3m model B4. (See the Planning permission & Building regulations advice sheet).
- ▶ It is strongly recommended that due consideration be made of the above points before deciding on where to position the garden room.

FOUNDATIONS

- ▶ Every site will be different, ranging from a level site to sloping, from firm ground, to soft ground or even very soft.
- ▶ Whilst we can make suggestions, we would always recommend you using an experienced competent builder who can advise. Our floors require a base to support a floor loading of 1.5kn/m².
- ▶ On good ground a well laid concrete flagged patio on 100mm of compacted hardcore will carry a heavy car without damage and is perfectly adequate for supporting a garden room.
- ▶ The important factors are to remove the top layer, the grass or topsoil.
- ▶ Then to dig out any soft material until firm ground is reached.
- ▶ Any back fill should be hardcore and well compacted.
- ▶ This applies if you are using pad foundations on uneven or soft ground or a fully paved base in flags or concrete. If you are using pads you must remove the top layer between them and put down a weed barrier material.
- ▶ Our steel joisted floor comes in panels which only need support at the corners. Each model has its own pad layout drawing so these can be prepared in advance and the building dropped on to them.

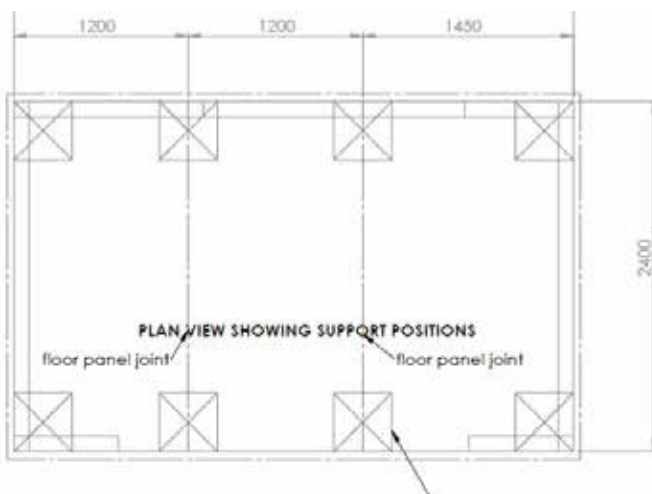

This shows the support positions required, the arrow indicates a padstone. These can be built from blocks to levels on site or proprietary.

One design of padstone that will support the required load is the 2.5t Easypad which comes with a levelling screw fitting for exact height adjustment.

They can be used at various levels as shown below and for more information look at easypads.co.uk



EASYPAD INSTALLATION GUIDE FOR SMALL GARDEN BUILDINGS



In order to help prevent the impact of seasonal movement on your foundations, we recommend that your foundations extend a minimum of 200mm into the ground. The depth of your footings will depend on the loads placed on the EasyPads and the ability of the ground to bear this load. The higher the load the bigger the footing. The poorer the ground conditions the wider and deeper the footings. The pads can sit on top of MOT or DOT compacted hard core. The EasyPads can be inserted into the ground or they can be surface mounted.

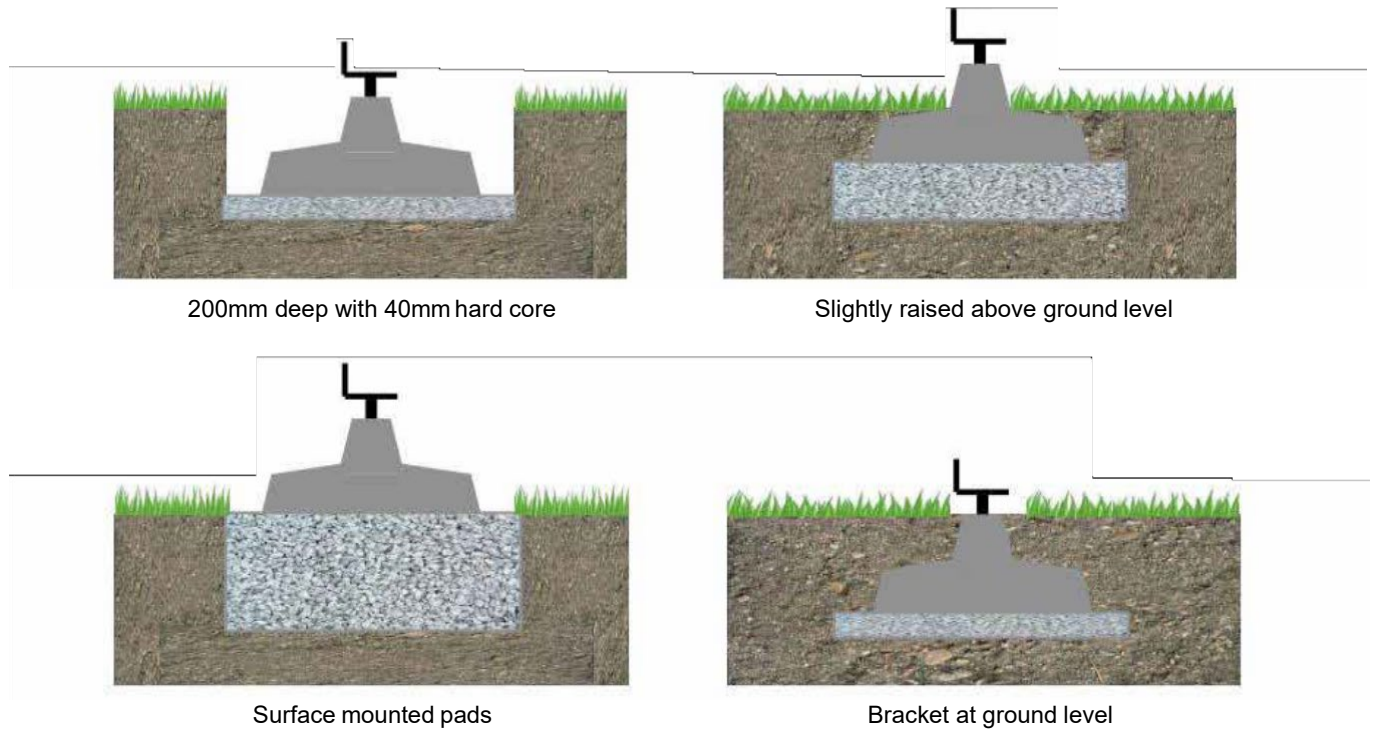

Clients are responsible for assessing their site ground conditions.

For traditional base construction, we also provide setting out drawings for each model as shown.

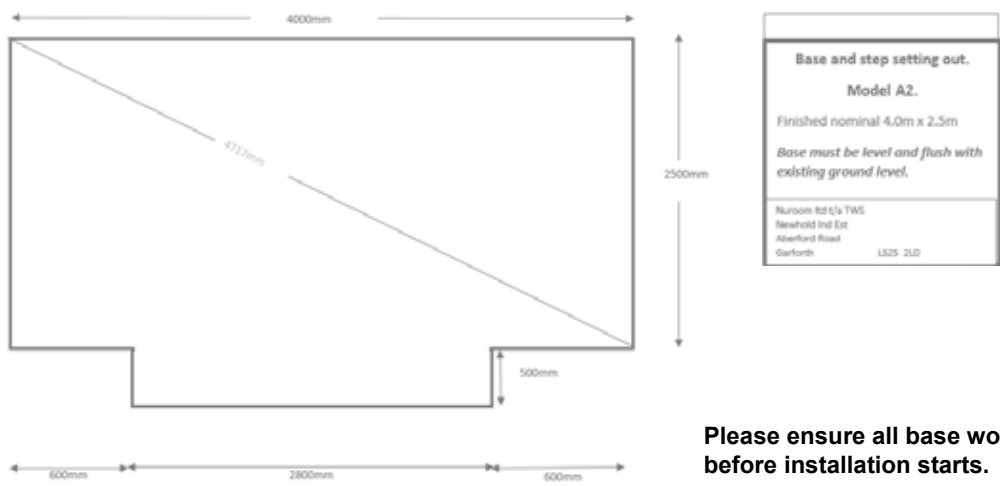

Please ensure all base work is given time to fully cure before installation starts.

FLOOR ASSEMBLY

1.0



Lay the steel floor panels out in ascending order, they will be marked with an FP number. If any of these panels contain braces ensure the braces face upwards.

2.0



Bolt the floor panels together using M16 Bolts, nuts and anti-shake washers through the provided holes, torque to 80NM.

3.0



Using 5.5mm Tek screws add two additional fixings equally spaced in between the floor bolts.

4.0

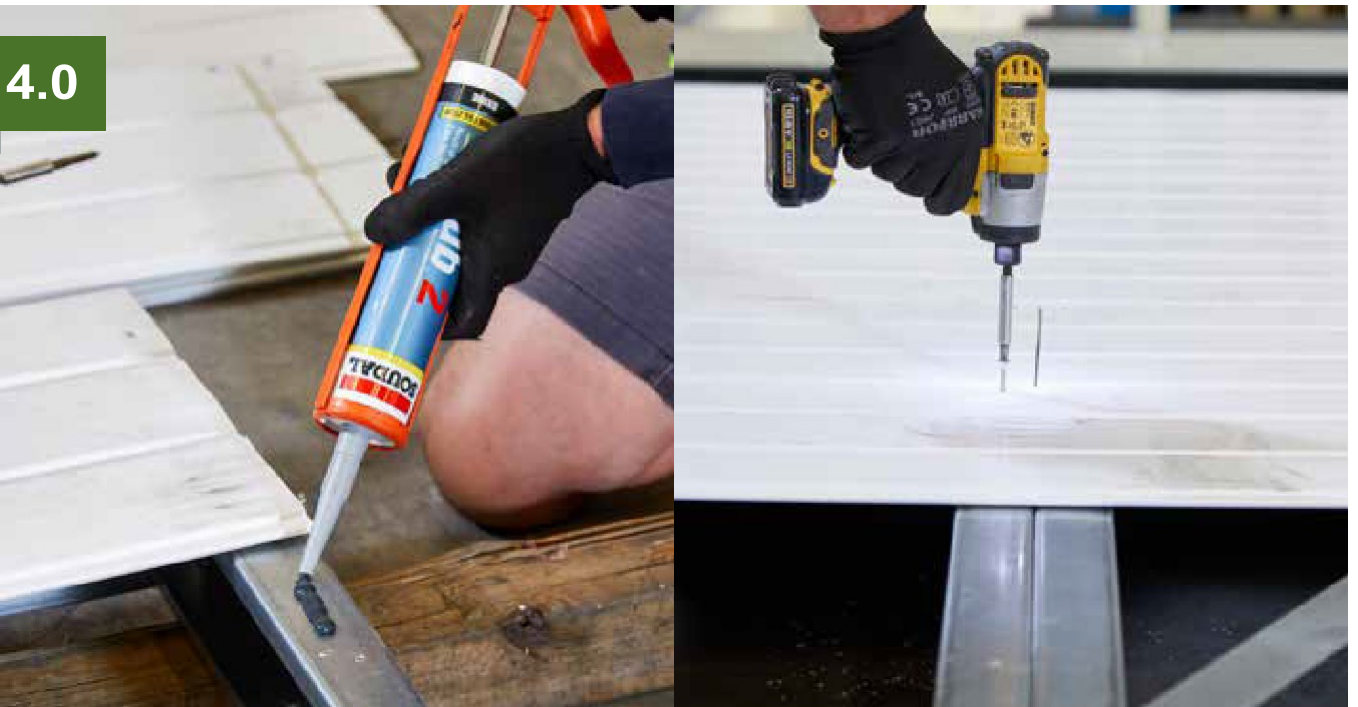

Run a generous bead of silicone sealant around the perimeter of the steel floor panels before installing the PVC cladding panels using 3.2x38Lg self drill screws. Fix around perimeter and to any intermediate joists. Note, on longer buildings this may required the operation being sequenced in manageable stages depending on how many operatives are in attendance.

5.0



Ensuring sufficient operatives are available flip the assembled floor panel and install the mineral fibre insulation into the cavity, ensuring its tucked into the section channels.

6.0



Lay the 20mm PIR insulation sheets out onto the assembled floor panel and trim to required overall size. Ensure the insulation joints fall over the intermediate joists and the overall size of the PIR insulation is flush with the steel floor outer edge. Ensuring the sheets are all positioned equal and square, foil tape the corners to the steel work to hold in place then foil tape all joints.

7.0



Consult the enclosed floor board layout drawing to correctly position the boards and cut to size, bond the boards together using D4 adhesive or equivalent and fix the boards to the steel work using 5.5 x 80mm CS winged tip self drill screws around perimeter and where boards pass over intermediate joists. Screws should be positioned 80mm from outer perimeter and 50mm from any intermediate joints. Bevell top external board edges 5mm all round to allow plastisol base trim to fit snugly.

8.0



Run a couple of beads of sealant/adhesive along the back of the plastisol base trim and install around perimeter.

9.0



Calculate the central position for the step assembly and mark a couple of reference lines.

10.0



Supporting the step assembly 43mm below floor level fix the step to the floor assembly using 5.5mm Tek screws, at least one per cross member and one each end.

11.0



Using adhesive install the plastisol floor corner trims.

WALL ASSEMBLY

12.0



Position two side panels, braces to outside where possible and then bolt together using steel box brackets and M16 bolts, nuts and anti-shake washers. On longer runs where two inline panels bolt together fix with two additional 5.5mm Tek screws in between the bolts.

13.0



Continue assembling the remaining sidewalls, then position and fix the front lintel using 4-off 5.5mm Tek screws into immediate side panels and 2-off 5.5mm Tek screws into any panels thereafter. Ensure the lintel is fixed so the ends are flush with the external edge of the front panels, this will set the width of the door aperture.

14.0



Position the wall structure equally and squarely onto the floor assembly, also check the door aperture across the base is consistent with the width under the lintel.

15.0



Once correctly positioned fix the side walls to the floor using 5.5 x 80mm CS winged tip self drill screw adjacent to each upright i.e approx 500mm ctrs, ensure the fixings are towards the outside to ensure they pick up on the steel floor edge section. Do not fix down where any windows are to be positioned later.

16.0



Install expanding foam to head of all wall panels.

ROOF INSTALLATION

17.0



Carefully lift and approximately position the first roofing panel on top of the wall panels, then run a generous bead of sealant along the top of the mating joint.

18.0



Offer up the next roofing panel ensuring any protective film is pulled back from the joint. Continue the process until all roofing panels are approximately positioned.

19.0



Now accurately position the roof panels, ensure the panels overhang the back wall by 117mm and the panels overhang equally on both sides.

20.0



Fix up through the sidewall heads into the roofing panels using the Evo+ Tek Screws at 500mm centres.

21.0



Fix the roofing panels through the top of every castellation into the rear wall head and front lintel using 180 x 5.4 self drilling Tek screws and then install the grey plastic cover caps.

22.0



Fix the end roof panels down to the side walls using 150 x 5.4 Tek screws in the trough area of the panels at 500mm ctrs as shown below, then install cover caps the grey plastic cover caps.

SIDE WINDOW PREPARATION

OPTIONAL

23.0



Optional, If side windows exist continue with point 23, else skip to point 24.

If the design incorporates side windows the base steel will already be partially cut, use a hacksaw to cut the remaining material and remove the steel section.

FIXING SIDE PANELS - PREPARATION FOR EXTERNAL CLADDING

24.0



Position the 20mm PIR onto the side walls and fix with limited tek screws to temporarily hold until battens can be fixed. The PIR should be flush with the front of steel work and 42mm lower than the wall panel base. Mark the position of the steel corner brackets and mullion centres onto the PIR for reference later.

25.0



Install the 20mm PIR to the front and start of the rear of the structure, align the insulation to the outside of the PIR fixed to the side. A 20mm Notch at the lintel position will aid the support of the insulation above the door later.

26.0



Apply foil sealing tape to all insulation joints, corners and around door/window apertures.

27.0

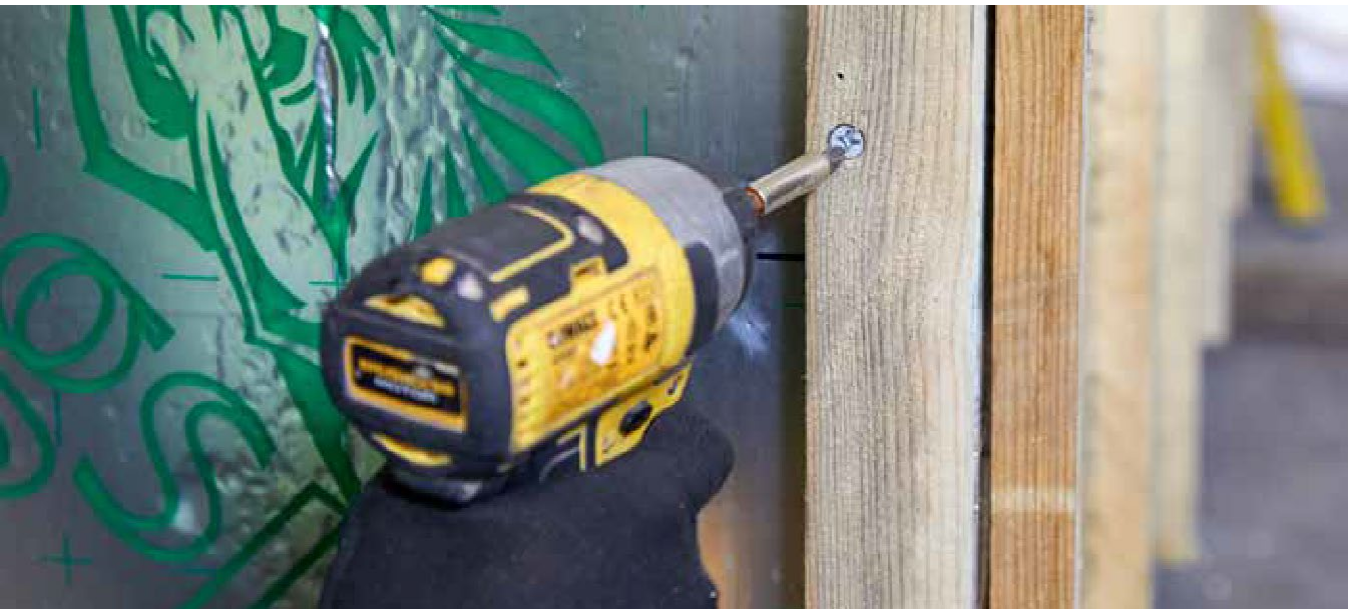

Install pre-cut 50x25 battens vertically over the steel mullion positions using 5.5 x 85mm CS wing tip self drill screws at 600 centres. Ensure the battens are accurately positioned 124mm up from the base of the garden room and are kept level. The battens should finish 26mm from underneath of roof. When fixing the corner battens position the screws away from the corner to ensure they pick up the corner brackets. It is advised to predrill the battens with a 6mm drill to avoid the screws binding.

28.0



Before installing the battens on the front walls either side of the doors, use a small amount of adhesive to hold the plastisol shadow trim in position. Ensure it is positioned tight the roof panel.

29.0



Position the aluminium starter trim to the base of the battens mark the fixing locations then drill and countersink, fix the trim using 25mm stainless counter sunk wood screws at each batten location.

30.0



Pilot and countersink the coastline head vent and fasten to the battens 25mm C/S wood stainless screws. Note the gap above the vent for ventilation.

31.0



Install the side barge trims through the top face into the top of the roofing panel using Evo+ Tek screws and grey plastic screw cover caps.

32.0



Drill and countersink the coastline edge and corner trims and fasten using 25mm C/S stainless wood screws.

SIDE WINDOW FITTING

OPTIONAL

33.0



Optional Extra – Side Windows. (Skip to 36 if not present).

If side window exists, mark and scribe the window cill then fasten to floor using screws.

34.0



Before installing window, run a bead of sealant across the back of the cill and cill to coastline edge trim joint. Fix the window ensuring it is positioned plum using fixings. Fixings should be 100mm from corners and maximum 600mm centres.

35.0



Install the steel plastisol trim above the window(s) using a suitable adhesive.

INSTALLING EXTERNAL DECKING

36.0



Fix the first decking starter clip inline with the front edge of the coastline edge trim using 3.2 x 38LG self drill screws. Ensure all following clips are kept inline.

37.0



Install the decking boards and use the plastic intermediate T brackets to fix down between each board using 3.2 x 38LG self drill screws.

38.0



Scribe the door cill and fasten the cill to the floor. Run a bead of sealant along the back of the cill and at the end of the cill up to the coastline edge trim. Then install the French doors using fixings 100mm away from the corners and 600mm centres. Ensure the glass is toe and heeled with packers before installing the glass.

FIXING EXTERNAL CLADDING

39.0



Install the coastline boards to the sides and back of the garden room using 25mm CS stainless screws into each batten, the boards will require bending to allow installation behind the edge and corner trims. Ensure the boards are installed horizontal and same height around corners.

40.0



The upper panels need a 15mm ventilation gap to the roofing panel, this will also allow the panel to be positioned and clipped down onto the below panel.

41.0



If the garden room incorporates a step, then the base coastline boards on the front of the garden room will require notching around the decking as shown below.

FITTING ROOF PANEL TRIM

42.0



Install the roofing panel foam filling strips, these are eventually clamped with the front trim but can be held with adhesive in a few areas if windy.

43.0



Install the front roofing panel barge fixing through into the roofing panel using Evo+ tek screws and cover caps, then use adhesive to install the corner cover caps and then use a Evo+ tek screw or grey pop rivet in the corner to hold the side barge, front barge and corner trim together. An additional pop rivet to the underside is recommended.

44.0



Install the steel plastisol trim above the doors using adhesive.



4 .0

Install the rear guttering ensuring the gutter brackets are fixed into the vertical battens behind the coastline trims. A slight vertical fall to the downpipe location is recommended.

4 .0

Install the rear roof barge trims using Evo+ Tek screw, at joints using 5mm drill pilot the top and bottom edge of the joint and pop rivet.

FITTING STEP TRIM

47.0



Run two beads of adhesive around the step and install step side trims.

48.0



Using adhesive fix the step corner trims in place.

49.0



Using Adhesive install the step edge trims, ensuring the corner mitres are together.

ELECTRICAL FITTINGS INSTALLATION

50.0



Route electrical cabling to suit desired locations of lights, sockets and consumer unit. The wiring must be installed by a qualified electrical engineer and comply with the 18th Edition of the IET Wiring Regulations BS7671:2018. Rubber edge protection trims are supplied and should be installed where any wiring passes around the sharp edges of the steel framework.

INSTALLING INSULATION

51.0



Install the mineral fibre installation into the side walls, ensure gloves are worn to avoid skin irritation.

52.0



Install mineral fibre insulation into the door lintel.

FLOORING INSTALLATION

53.0

PREPARATION

1. The floor should be fitted at a room temperature of minimum 18°C/62°F and maximum 27°C/80°F.
2. The materials should be acclimatised for a period of 24 hours prior to installation.
3. Before installation, check all panels in daylight for possible defects or discrepancies in batch, colour or shine.
4. Check that the tongue and groove of the click profile is free from dirt and undamaged.
5. For best results mix at least two packs when fitting to avoid repetitions in the pattern. It is also preferable to only use material from the same batch in a single room.
6. The surface beneath the floor must be sufficiently prepared in advance to guarantee successful fitting of the floor covering. In particular, it must be clean, dry, smooth, firm, level, free from defects and not contaminated with grease, oil or chemicals. Unevenness of the subfloor in excess of 3mm over a 3m length must be levelled with an appropriate levelling compound. If you are uncertain of the requirements, please contact your retailer who can confirm the exact requirements.
7. The finished appearance of a Moduleo® Click floor will only be as good as the quality of the sub floor over which it is installed. Any irregularities in the sub floor may show through the finished floor.

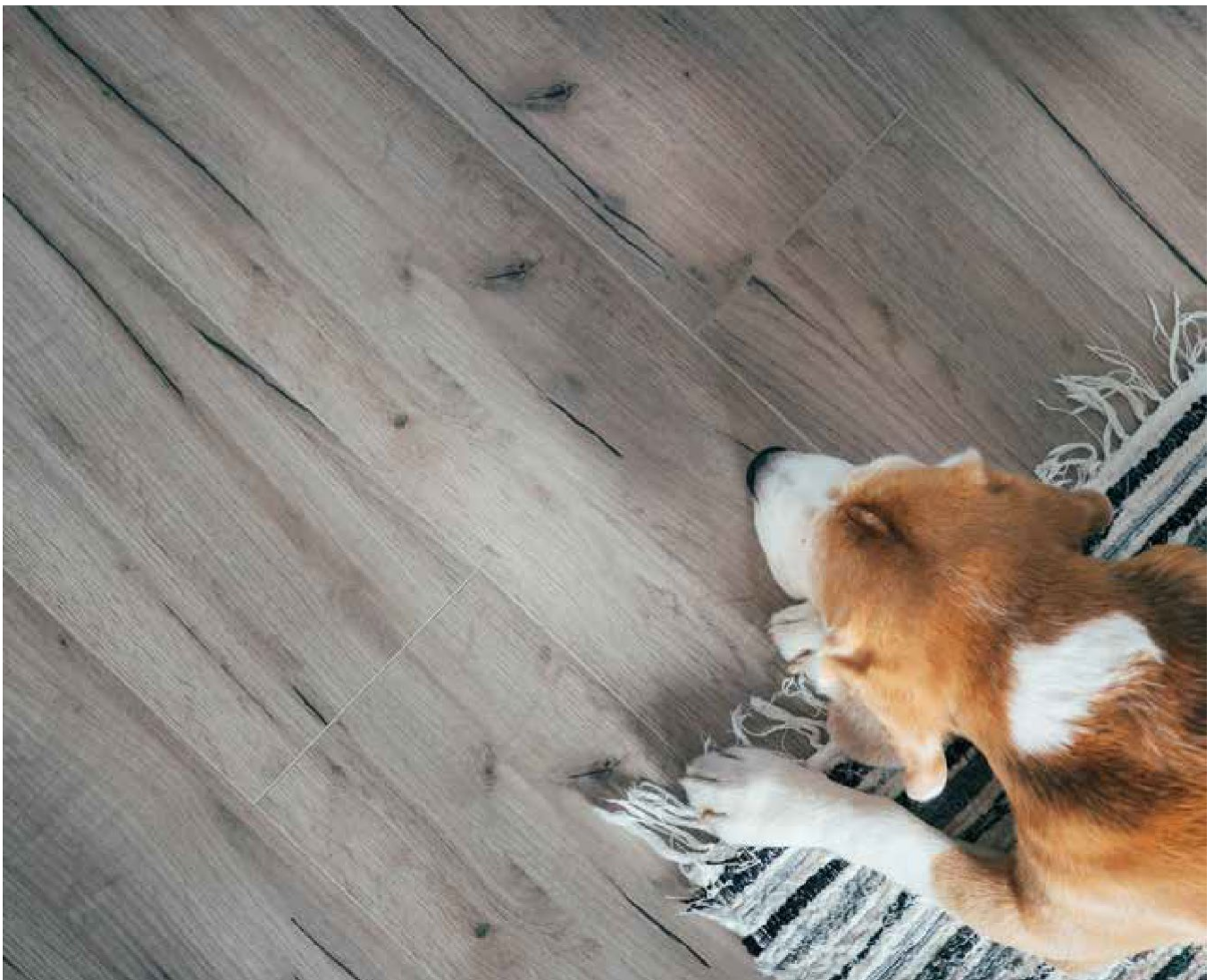

STEP-BY-STEP FITTING INSTRUCTIONS

Moduleo® Click is a “floating” floor. Never glue or fix the panels to the surface below.

The flooring can be installed wall-to-wall; however, it is advisable to incorporate a 5mm expansion gap at the perimeter of the room.

Where the floor may be exposed to unusually wide temperature ranges (such as where under floor heating is used or areas adjacent to a south facing window), then it is necessary to use a 5mm space around the edge, as appropriate.

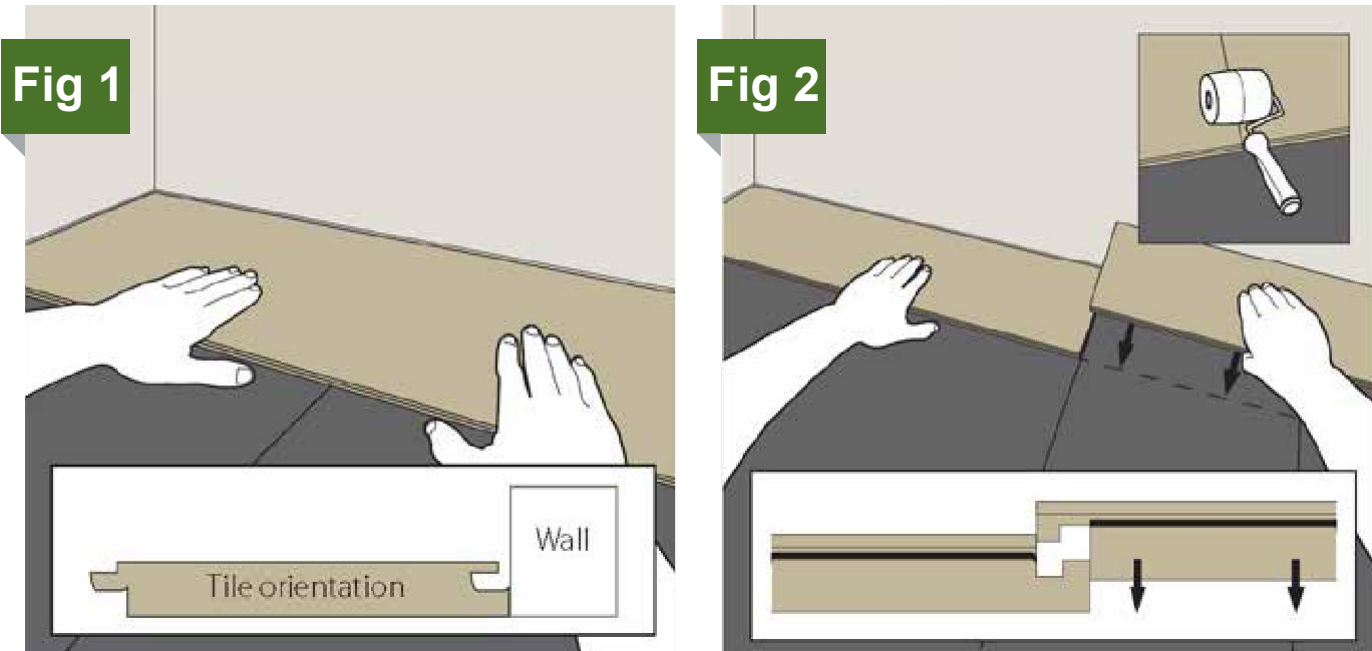

1. Measure the room carefully to determine the central axis, from which the first row to be laid is outlined.
2. Check whether the first row of panels needs to be narrowed. If not, the lower groove lip of the first row of panels needs to be removed. Use a utility knife to neatly cut off the lower groove lip.
3. First install the Xtrafloor underlay in accordance with the instructions, ensuring the shiny side is upper most.
4. Begin by peeling back the protective cover on the Xtrafloor underlay and lay the first row in the corner of the room on your left hand side as you are looking at the wall. Always work from left to right and with the tongue towards yourself. Figure 1.
5. Lay the first row in a straight line and click the head ends together. Put the short side of the profile into head end of the previous panel and press the panel downwards. It is recommended to use a hand roller for connecting the head ends so that the joint fits securely. Continue laying the first row in the same way until you get to the last piece. Figure 2.

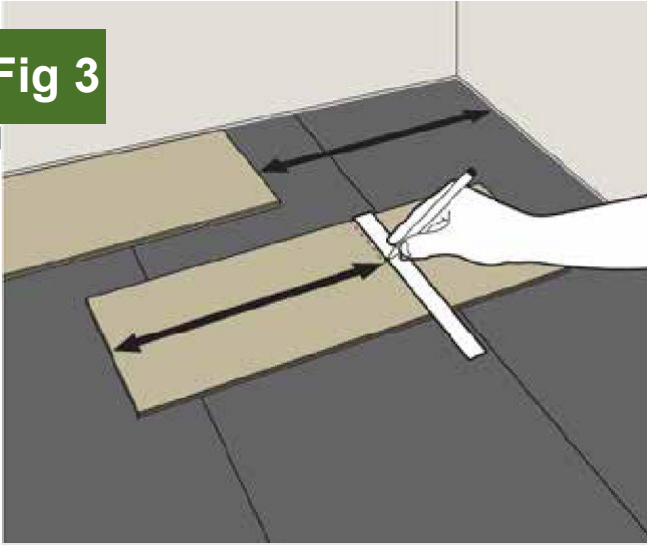
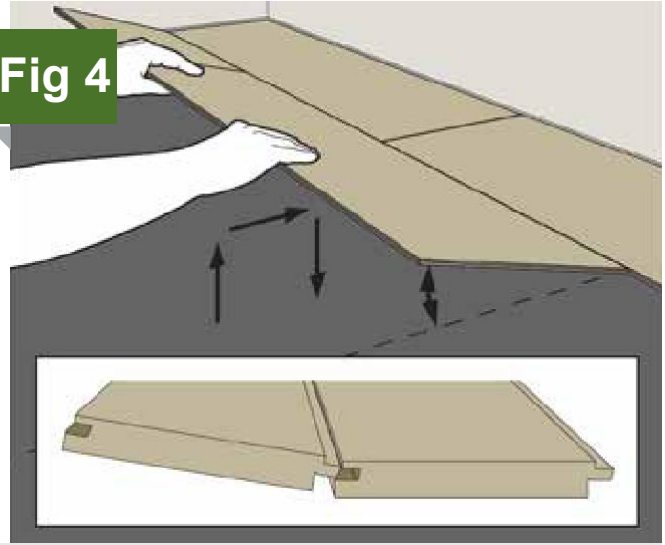
Fig 3**Fig 4**

6. For the last piece, measure the last plank to ensure a tight fit to the wall. Then cut away the marked piece and fit the end panel in the same way as the previous panels. When cutting the panel with a utility knife, make sure that you cut through the wear layer before breaking the panel. Figure 3.
7. For an attractive and natural appearance, we advise you to use the piece left over from row 1 as the first piece in the next row, as long as the remaining piece is at least 1/3 of the total plank length. Do this for all subsequent rows.
8. Fit the second row as you did for the first: start on the left side and slide the groove of the panel under an angle of about 25° over the tongue of the previous row and click the groove into the tongue by laying down the panel while pushing it firmly against the first row. Figure 4.

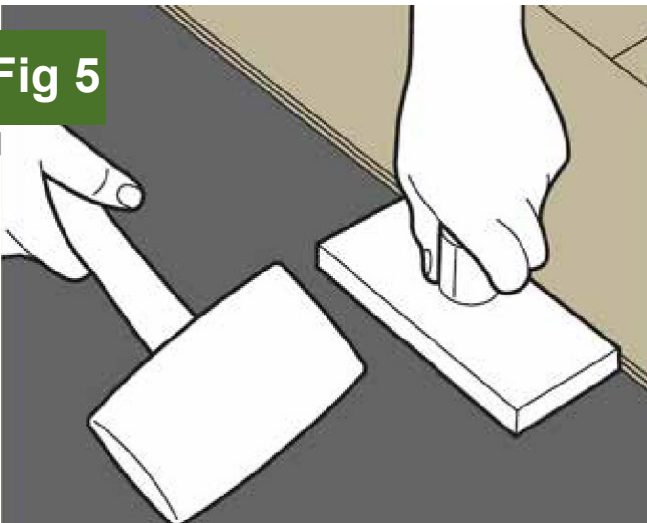
Fig 5**Fig 6**

9. Then fit the second panel by sliding the groove under at an angle of 25° into the tongue of the previous row. Position the corner of the head end against the previous panel and then drop the short side of the profile into the head end of the previous panel and push downwards. Use a hand roller for connecting the head ends so that the joint fits securely. Repeat until you reach the end of the row. To ensure a firm Click installation, it is recommended that the planks are tapped together along the long edge with a tapping block and a rubber mallet. This will ensure that the Click mechanism is firmly locked during installation, providing a secure joint and avoiding any movement after the installation has been completed. Figure 5.
10. To fit the last row of panels you will usually need to narrow them. Do this as follows: lay a panel on top of the previous row with the groove towards the wall, lay another panel upside down up to the edge of the wall and mark the panel underneath. Cut the panel to size and fit the last row. Figure 6.
11. Door posts and heating pipes also need to be individually fitted. First cut the panel to the right length. Then place the panel next to the object and draw the correct fitting. Next, cut the panel to size. Door posts can also be sawn to size if necessary to lay the floor beneath them. For cutting around difficult areas such as door posts, heating pipes and other interior furniture; the use of a Jigsaw with the correct plastic cutting blades is suitable and will avoid unsightly cuts at the perimeter of the room.

INTERNAL CLADDING INSTALLATION

54.0

PREPARATION

Ensure battens are kept dry upon delivery, if battens are damp, it is advised to let them dry and normalise to the internal climate for 24 hrs before installing.

Before installation of the internal cladding preparation for the electrical socket needs to be performed. The electrical boxes require fixing to timber OSB boards supported between the steel framework. Ensure the position will allow for the electrical box to be behind the front face of the decorative cladding. You may also required additional battens directly behind the cladding for the installation of the consumer unit.

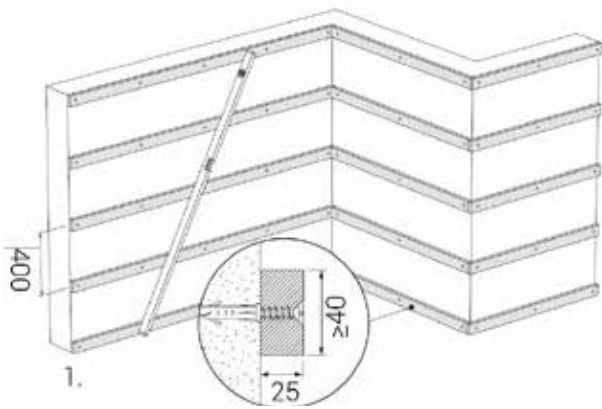

- ▶ Install 25x38mm Battens horizontally at 400mm centres using ??x?? self drilling screws through the battens into the steel structure.

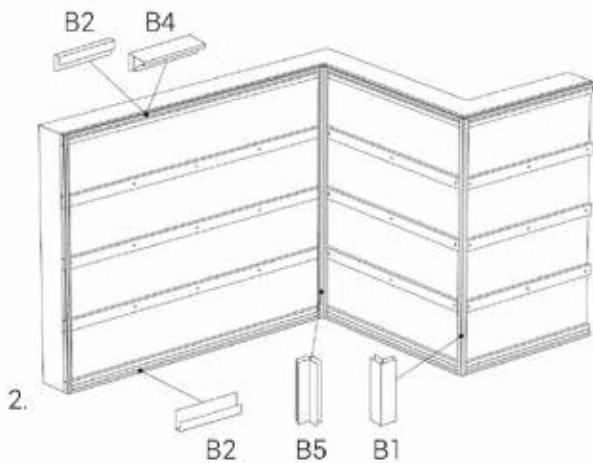

- ▶ Install the necessary corner and edge trims to the battens using ?? fixings.

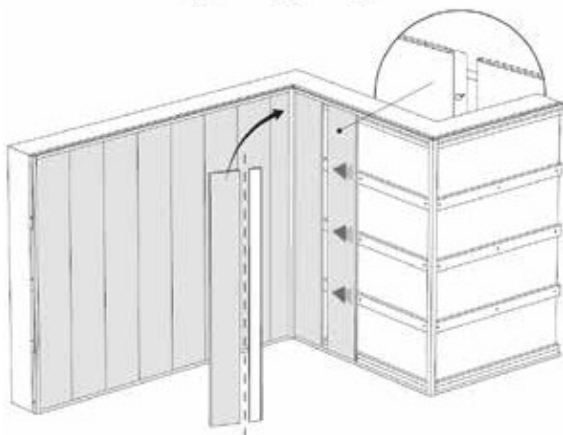

- ▶ Install the Vilo panels vertically, fixing at each batten location using ?? fixings.

ROOMLINE SKIRTING INSTALLATION

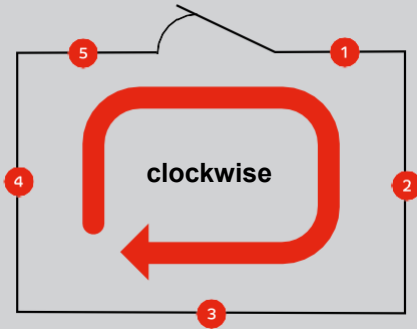

PLEASE NOTE

If you are planning to lay a new laminate or tiled floor, do this **before** fitting the skirting board for the neatest finish

If you are carpeting, fit the skirting boards **first**

Always fit Roomline skirting boards from the door opening in a **clockwise** direction

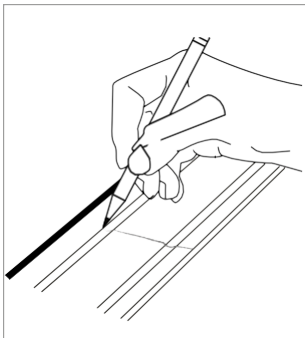

Figure 1

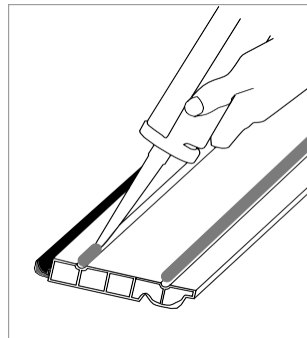

Figure 2

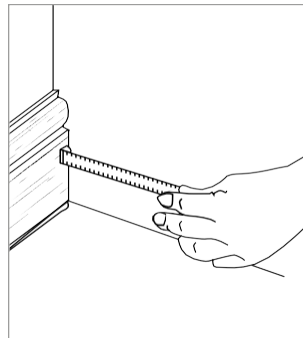

Figure 3



Figure 4

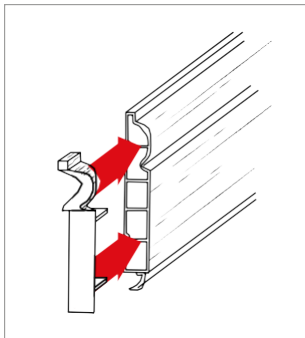

Figure 5

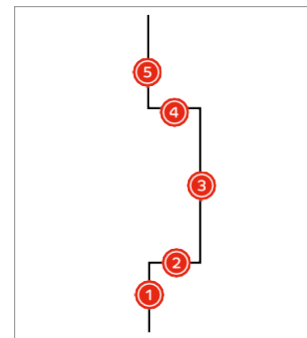

Figure 6

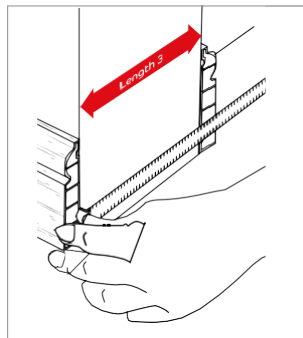

Figure 7



Figure 8

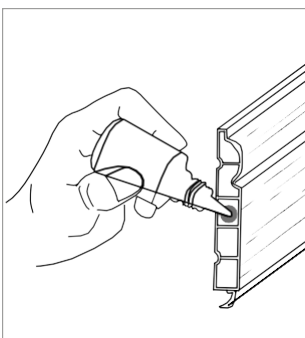

Figure 9

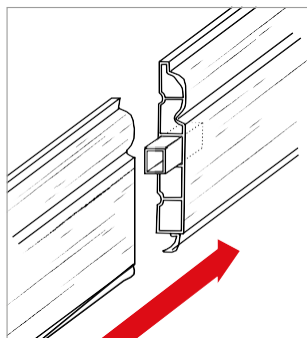

Figure 10

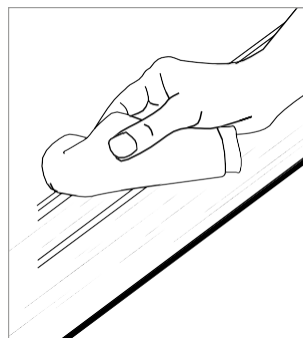

Figure 11

56.0

FITTING

- ▶ **1.1** Measure length 1 from the external edge of the architrave to the inside corner of the room. Transfer this measurement onto a length of skirting board and mark accurately with a pencil. Cut the skirting board to length using square cuts with the aid of a fine toothed saw and saw block. Position the skirting board to check length. See Fig 1.
- ▶ **1.2** Lay the skirting board on its face and apply a bead of SilverSil Never Nails or another contact building adhesive down each adhesive channel. Place the skirting board in position pushing firmly back to the wall. See Fig 2.
- ▶ **1.3** Measure length 2 from the flat face of the skirting board to the inside corner of the room. Cut to length using square cuts. See Fig 3.
- ▶ **1.4** Apply contact adhesive to the scribed internal corner moulding (available from your local Eurocell Building Plastics branch as part of the corner trim kit) and push onto the left hand end of the cut skirting board. Position the skirting board to check for length and trim if necessary. Once satisfied repeat stage 2. See Fig 4.
- ▶ **1.5** Repeat this process until the room is complete.

2. External corners - see Figure 6 for example

- ▶ **2.1** Measure from the flat face of skirting board 1 to the external corner of the wall. Cut the skirting board using square cuts. Fit a scribed internal corner moulding to the left hand end and check for fit. If satisfied fix in position with adhesive. See Fig 5.
- ▶ **2.2** Measure length 4 from the inside corner of the room to the external corner of the room. Cut to length using square cuts. If satisfied with fit fix to wall using adhesive.
- ▶ **2.3** Measure length 3 from the inside faces of fitted lengths 2 & 4 and square cut to length. See Fig 7.
- ▶ **2.4** Apply adhesive to the external corner mouldings and push fit onto each end of length 3. Apply adhesive to the back face of the skirting board and the remaining tabs of the corner mouldings and fix into position making sure that the tabs locate into their correct position within the previously fitted lengths 2 & 4. Wipe off any surplus adhesive. See Fig 8.

3. Inline joints

- ▶ **3.1** Cut the required lengths of skirting board to be jointed with accurate square cuts. Apply adhesive into the correct cavity of one cut length. See Fig 9.
- ▶ **3.2** Push fit the in-line joint moulding so that half the moulding is inside the skirting and half protrudes. See Fig 10.
- ▶ **3.3** Apply adhesive into the other length to be jointed and push fit onto the moulding until a tight fit is achieved. Wipe off any excess adhesive. Once jointed the length can be fitted in the conventional manner.

4. Maintenance

- ▶ **4.1** Roomline products are designed for minimal maintenance. All they require is the occasional wipe over with household polish or a damp cloth. Stubborn marks can be removed using a non abrasive cream cleaner, such as SilverSil Cream Cleaner. The use of chemical based cleaners or abrasive materials is NOT recommended. See Fig 11.



DESIGN GRID

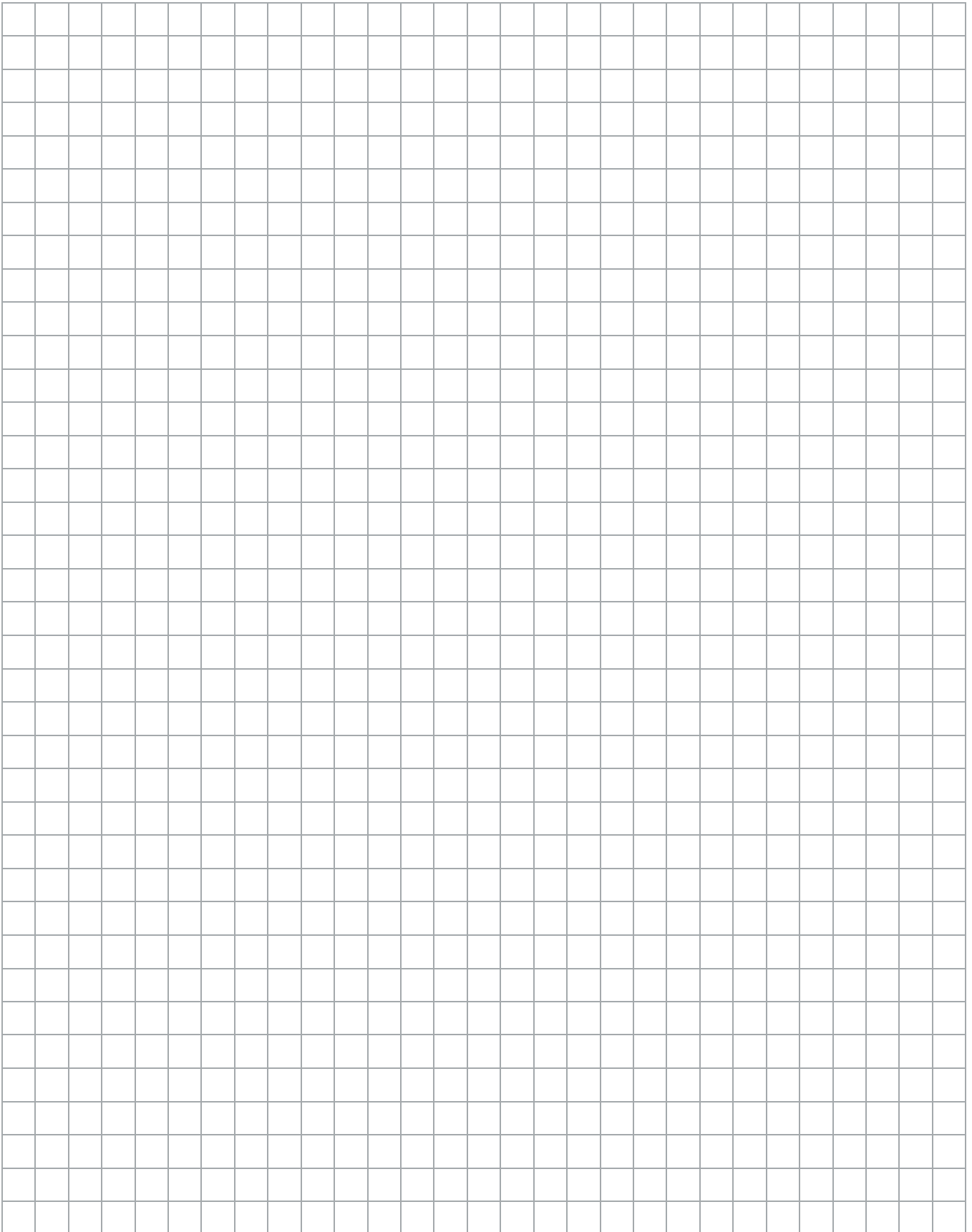

DESIGN GRID

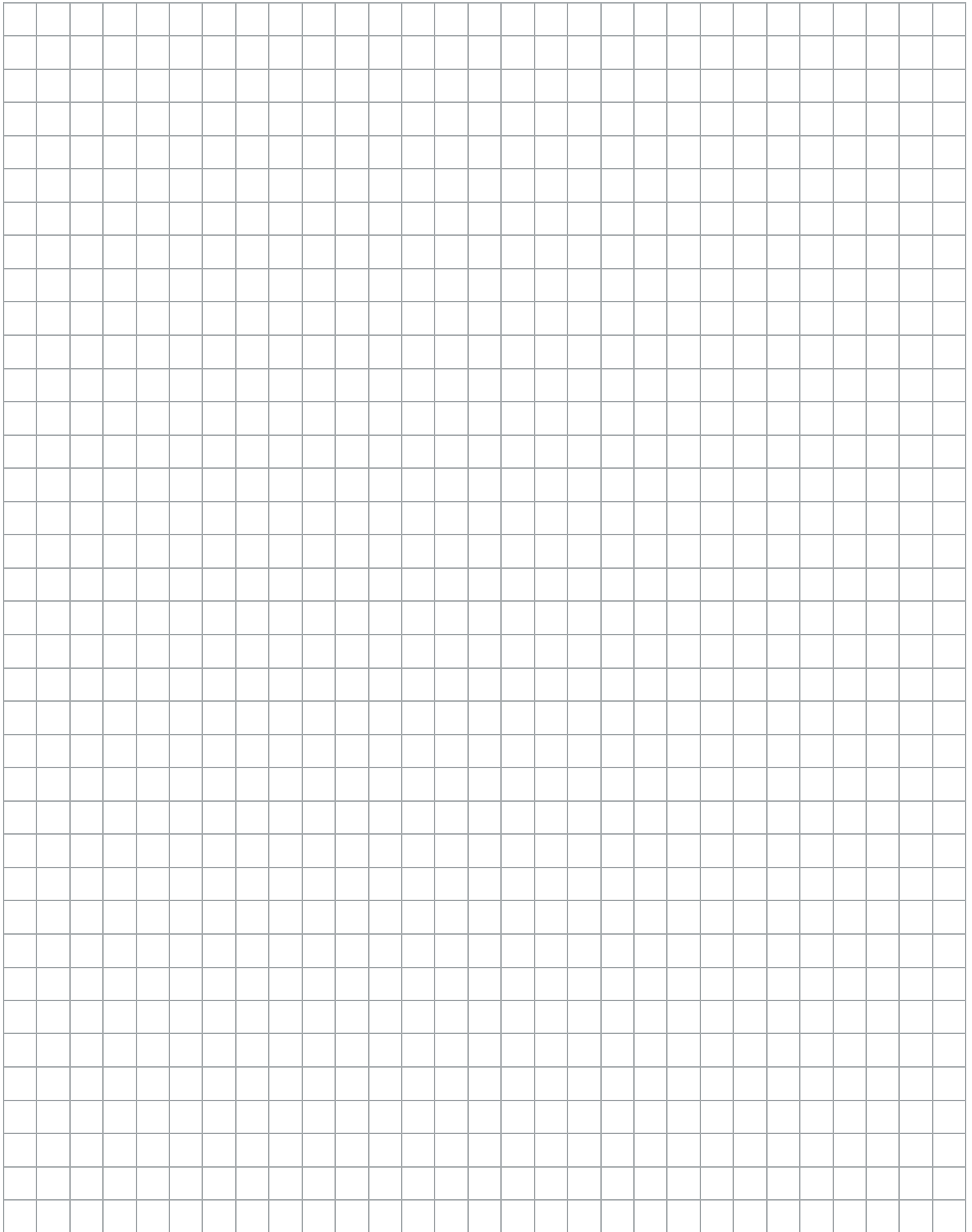

DESIGN GRID

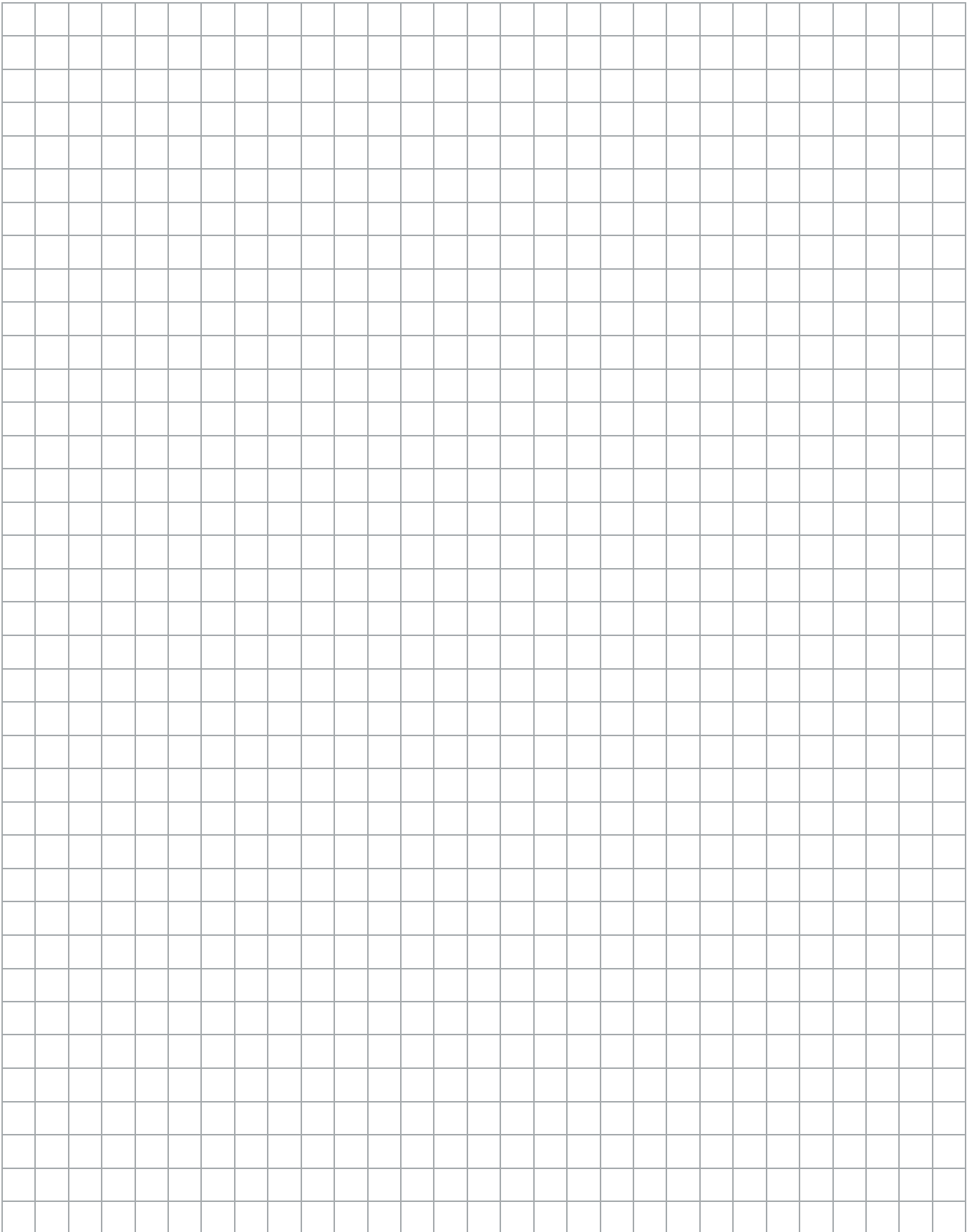

CONTACT

For further information, contact the Midbrook Technical Team on **01335 370128**.

Product specification is subject to change without notification. Please also note that colours shown are illustrative only, as the printing process does not allow 100% accurate colours to be reproduced.